

BASIC SYSTEM SPECIFICATIONS

- GRINDER UNIT - SINGLE 100 H.P. BELT TYPE AS MANUFACTURED BY G & P WITH ONE 12" WIDE BELT
- BELT SPEED 2000 TO 6500 SFPM VIA VARIABLE FREQUENCY DRIVE UNIT
- BELT SURFACE GRINDING AREA AT 1 TO 1 1/2 SQUARE INCHES
- HORIZONTAL FORCE AT 8 - 13 LBS PER H.P. (800 - 1300 #)
- GRINDER LEVEL THRU MOTOR DRIVEN SCREW JACKS WITH DIGITAL READOUT AT CONTROL STATION
- GRINDING FLUID SPRAY THRU MULTIPLE HEADERS AT BELT PULLEYS AND GRINDING POINT
- OPERATOR TO SET HEIGHT OF GRINDER FOR INITIAL GRINDING POSITIONING
- GRINDER LIFTING TRAVEL TO BE 18 INCHES THRU FOUR 5 TON SCREW JACKS WITH COMMON DRIVE
- LIFTING GUIDES THRU FOUR 3" HEAVY DUTY LINEAR BEARING VERTICAL POSTS
- GRINDER SUPPORT TROLLEY - TWIN PATENTED TRACK UNDER RUNNING SET-UP
- TROLLEYS TO BE 4 WHEEL IDLER UNITS AT 4 CORNERS OF TROLLEY FRAME
- TROLLEY DRIVE VIA TWIN RACK AND PINIONS WITH COMMON CENTER DRIVE
- UPLIFT RETENTION BY TWIN PINIONS UNDER DRIVE RACK
- TROLLEY SPEED AT 12 FPM MAX. WITH VFD AND ENCODER FOR INDEXING
- GANTRY BRIDGE - WELDED STEEL STRUCTURE WITH PATENTED TRACK TROLLEY RAILS AT 84" CENTERS
- GANTRY TRAVEL ON GRINDER TABLE AT APPROXIMATELY 90 FEET
- GANTRY SPAN AT 25 FEET WITH 126" ACE END TRUCKS
- GANTRY DRIVEN THRU TWO INVERTER DUTY DRIVES - ONE EACH END TRUCK
- BASIC GANTRY TRAVEL SPEED AT 5 - 75 FPM THRU VFD MAX. SPEED AT 100 FPM FOR SET-UP ONLY
- BASE SPEED AT 60 HZ TO BE 50 FPM - LOCATION THRU RACK & PINION ENCODER
- GRINDER TABLE - AREA TO COVER 26 FEET x 125 FEET BASE SET-UP AT 12" THICK WITH SUMP BEYOND TABLE
- STEEL AND REINFORCED CONCRETE TABLE TO SET ON CUSTOMERS SUPPLIED 12" REINFORCED FLOOR SLAB
- GANTRY RAILS AT 25 FOOT CENTERS WITH CLAMPING RAILS AT 12 FOOT CENTERS ALONG TABLE LENGTH
- FLUID DRAINS PROVIDED SLOPING TOWARD SUMP AT TABLE END
- POWER, CONTROL & FLUID FEED - THRU POWER TRAK SET-UP MOUNTED ALONG BUILDING COLUMNS THEN TO GRINDER THRU POWERTRAK AND CABLE DROPS
- GRINDER FLUID - SPRAYED THRU MULTIPLE HEADERS ONTO THE BELT PULLEYS TO MINIMIZE BUILD-UP AND TOWARD THE POINT WHERE ACTUAL GRINDING BELT CONTACT OCCURS
- TABLE TRENCH FLUID - FLUID SPRAYED INTO TRENCH ENDS THEN GRAVITY DRAINED DOWN TRENCHES IN TABLE TO SUMP - THEN PUMPED FROM THE SUMP BACK TO THE GRINDER UNIT AT ABOUT 20 GPM MAX.
- POWER -----460 VAC-60 HZ-3 PH
- CONTROL -----110 VAC-60 HZ-1PH CONTROL STATION ON GANTRY
- CONTROL STATION - TRAVELING STOOP MOUNTED ON THE GANTRY END TRUCK - TOUCH SCREEN CONTROL STATION MOUNTED -ON THE GANTRY SUPPORT POST ABOVE THE STOOP
- OPERATION -----MANUAL SET-UP OR AUTOMATIC ONCE THE OPERATOR SETS UP THE PLATE PARAMETERS AND SELECTS -AUTOMATIC IN LIEU OF MANUAL.
- OPERATOR SHOULD NOT RIDE WITH THE GRINDER WHILE IN AUTOMATIC MODE-
- EMERGENCY STOPS - E-STOPS ARE LOCATED ON THE ACTUAL GRINDER ON BOTH SIDES ALONG WITH AN E-STOP AT ALL FOUR -CORNERS OF THE GANTRY STRUCTURE. AN E-STOP IS ALSO ON THE CONTROL STATION

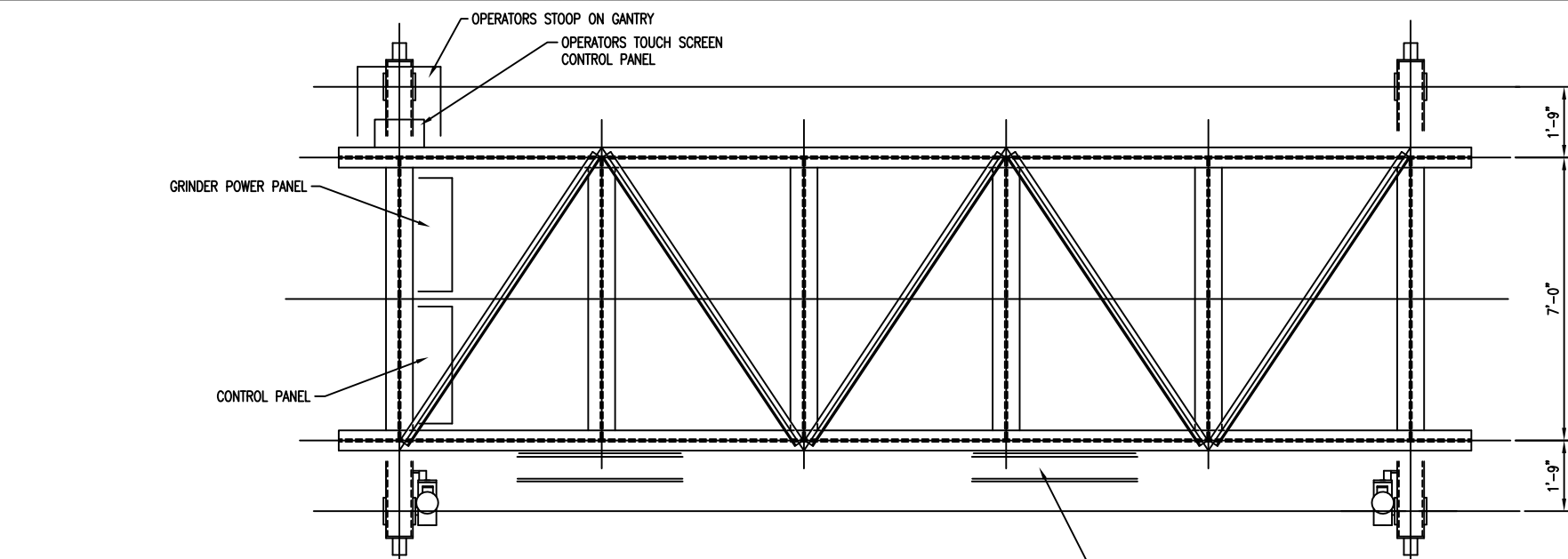

GANTRY PLAN

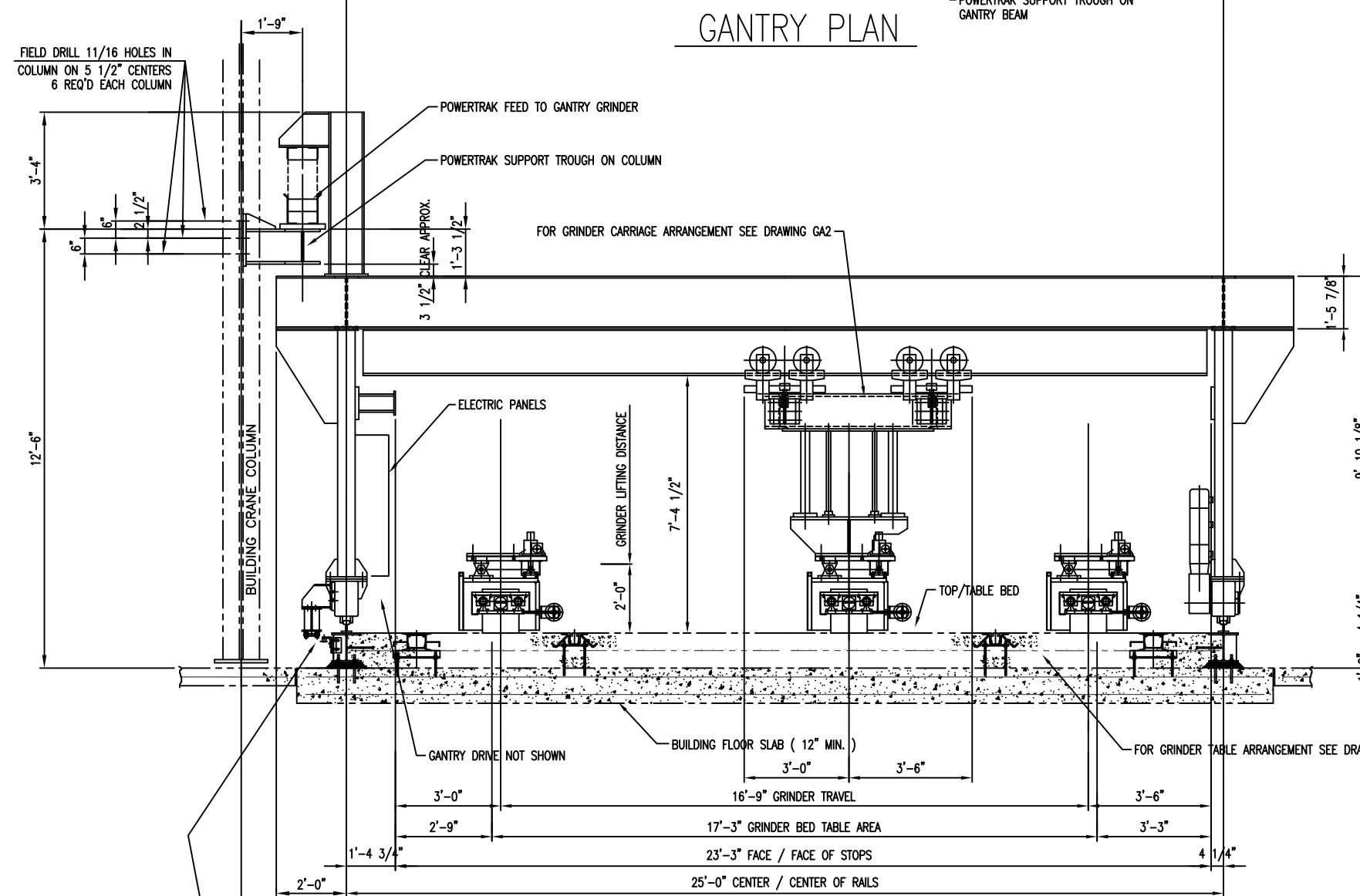

GANTRY ELEVATION

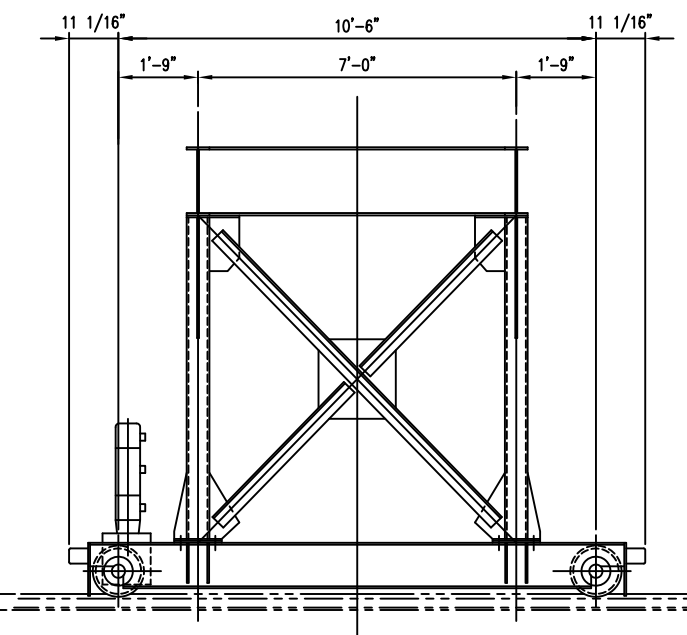

GANTRY END VIEW

REFERENCE DRAWING LIST

- GA1 GANTRY ARRANGEMENT
- GA2 GRINDER SUPPORT TROLLEY ARRANGEMENT
- GA3 GRINDER SUPPORT TROLLEY ARRANGEMENT SECTIONS
- GA4 GRINDER SUPPORT TROLLEY DRIVE DETAILS
- GA5 GRINDER SUPPORT TROLLEY LIFT DRIVE DETAILS
- GA6 GANTRY TRAVEL POSITION ENCODER LAYOUT
- E1 THRU E20 ELECTRICAL ARRANGEMENTS
- A1 PRE-BOND GRINDER TABLE ARRANGEMENT
- A2 PRE-BOND GRINDER TABLE ANCHOR BOLT ARRANGEMENT
- A3 PRE-BOND GRINDER TABLE ARRANGEMENT DETAILS
- A4 PRE-BOND GRINDER TABLE POWERTRAK SUPPORT STEEL

APPROVED	ISSUE	REVISIONS	 PITTSBURGH DESIGN SERVICES INC. P.O. BOX 469, CARNEGIE, PA. 15106 PHONE: (412) 276-3000	ENGINEERING/CONSTRUCTION DIV.	
	A	1		DATE	CONTRACT No.
	B	2	SCALE 1/2" = 1'-0"	DRAWN RJ BANKS	DWG. No. S-GA1
	C	3	DRAWN		
	D	4	LATER	CHECKED	
	E	5	LATER		
	F	6	100 HP G&P SINGLE BELT GRINDER GANTRY UNIT SINGLE BELT GANTRY GRINDER GENERAL ARRANGEMENT		